

PRODUCT BULLETIN

Features & Benefits:

- Combines impact milling and air classification technologies
- Air swept design prevents heat build up
- Low operational and maintenance costs
- Machine can be easily disassembled for cleaning and servicing
- Easily adjust PSD for efficient milling
- No screens to blind or tear

The FCM Air Classifier is a classifying impact mill capable of reducing powders down to 10 microns. It is fast becoming the workhorse in particle size reduction applications due to its combination of impact milling and air classification technologies in a single unit. The FCM's flexibility of operation allows it to easily process a multitude of product categories requiring efficient and economical particle size reduction for a broad range of industries including pharmaceutical, food, chemical, mineral and others.

How it Works:

The FCM Classifier Mill is a high speed impact mill with an internal air classifier. The material enters the grinding chamber through the feed inlet where it comes into contact with a series of spinning impact pins or blocks smashing the material into fine particles. The fine particles must pass through a cage of spinning blades, known as the "classifier wheel". The wheel acts as a screen and only lets the particles that are small enough to pass through, it also rejects the large particles causing them to stay in the mill for additional grinding. The fine particles then exit the mill and are collected in a bag house product collector. Particle size is easily adjusted by increasing or decreasing the classifier speed, without mill shutdown to achieve the desired PSD. Other system parameters are easily adjusted to allow for tight control of product size for grinding and classifying of a variety of materials.

Applications:

- Food Products
 - Sugar
 - Starches/Proteins
 - Wheat Gluten
 - Nutraceuticals & Vitamins
- Minerals
 - Chemicals
 - Agricultural Chemicals
 - Insecticides
 - Pesticides
 - Herbicides
 - Organic/Inorganic Fertilizers
- Dairy Powders
 - Lactose
 - Caseins
 - Calcium
 - Whey Proteins
 - Baby Formula

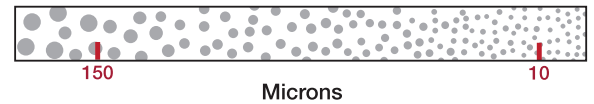
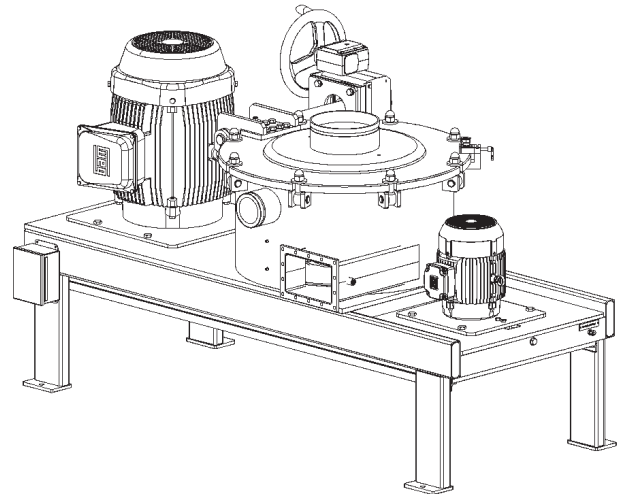

Product Fineness: 150 µm - 10 µm
Capacity Range: 15-18000 lbs/hr / 7-8165 kg/hr
Size Range: 1.5-500 HP / 1.1-373 kW
Air Flow Range: 80-13000 CFM / 150-22000 m³/h

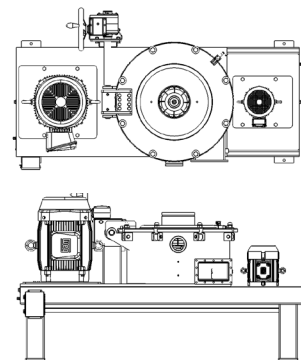

FCM AIR CLASSIFYING MILL

MILL SIZE	MILL CHAMBER		ROTOR DRIVE		CLASSIFIER DRIVE		ROTOR SPEED (RPM)	TYPICAL AIRFLOW		CAPACITY	
	(MM)	(IN)	(KW)	(HP)	(KW)	(HP)		(m ³ /h)	(CFM)	(LBS/HR)	(KG/HR)
FCM 100	100	4"	1.1-1.5	1.5-2.0	0.37-0.55	0.5-0.75	10000-24000	150	80	15-50	7-23
FCM 200	200	8"	2.2-3.8	3-5	0.75-1.1	1.0-1.5	6000-12500	400	250	30-180	14-82
FCM 350	350	14"	15-22	20-30	2.2-3.0	3-4	3000-8500	1400	800	200-1200	91-544
FCM 500	500	20"	30-45	40-60	5.5-7.5	7.5-10	2500-5000	2600	1500	400-2400	181-1089
FCM 650	650	25"	45-75	60-100	7.5-11	10-15	2000-4200	4500	2700	750-4500	340-2041
FCM 800	800	31"	75-122	100-150	11-15	15-20	1500-3200	6500	3800	1000-6000	454-2722
FCM 1000	1000	39"	112-218	150-300	15-22	20-30	1000-2600	12000	7000	1500-9000	680-4082
FCM 1400	1400	55"	228-375	300-500	30-55	40-75	1000-1850	22000	13000	3000-18000	1361-8165